

Chapter 5: Diodes

This week we will explore another new passive circuit element, the diode. We will also explore some diode applications including conversion of an AC signal into a signal that never changes polarity. To go beyond this and make a real DC signal will take a few more tools including low-pass filters.

I. Theory

Nonlinear Devices

The diode is our first nonlinear circuit element. A nonlinear element passes a current that is not proportional to the voltage across it (i.e. it does not obey Ohm's Law). Note, though, that a small change in the voltage across a diode will still generate a small change in its current. That is, if the change in voltage is small enough that the change in current will be proportional to that small voltage change. Thus, even circuits with diodes can use a Thevenin model for small deviations from the quiescent (or normal) condition of the circuit.

Diodes

Diodes are an important component of a DC power supply since they can convert an alternating current to a direct current. Most of the time, we will model a diode as simply a one-way gate for current.

In most wires and resistors, current is carried exclusively by electrons, which have negative charge. Semiconductors (silicon based devices) can use either negative charge carriers (electrons) or positively charged carriers (called holes) depending on what impurities have been added to the silicon when it was grown into a crystal. One type of impurity (called *n* doping) creates the negative carriers, and the other type of impurity (called *p* doping) creates positive carriers. A junction between *p*-doped and *n*-doped silicon makes a diode. Electrons and holes can easily recombine with each other at a *pn* junction producing a net current flow from *p* to *n*. However, if the current wants to flow in the other direction, so that both electrons and holes move away from the junction, then the junction will act like an open switch. Thus, diodes are simple devices with the remarkable property that they only conduct current in one direction.

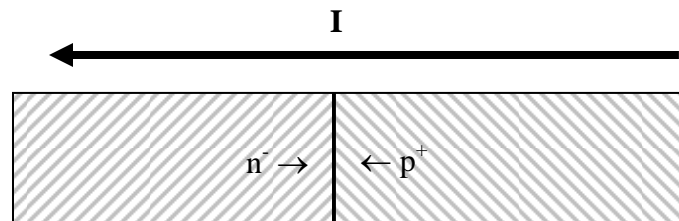

Holes and electrons recombine to let current flow

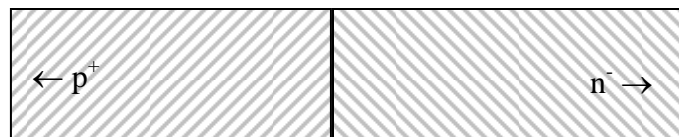

Current cannot flow the other way, since there is no energy source to create holes and electrons.

Diode Model 1: The current gate

For almost all practical purposes, we will treat a diode as a one-way current gate that also produces a 0.6 V voltage drop for silicon and 0.2 V drop for germanium. The voltage drop is due to the energy converted to heat as the electron-hole pair recombines. Diodes have a marking on them (sometimes just the line at the output end), showing the direction they conduct. In the accompanying figure, the diode will only conduct if $V_{IN} > 0.6$ V. When the diode does conduct, any excess voltage drop shows up across the resistor. In other words, the diode just conducts enough current to set I such that

$$IR = V_{IN} - 0.6 \text{ V}$$

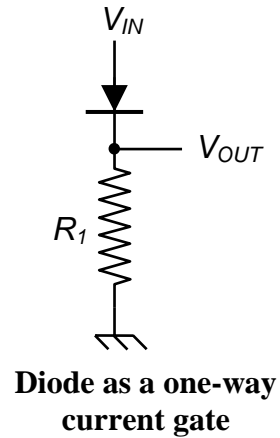

Diode Model 2: The Ebers-Moll model

A more complete model of a diode would treat the resistance of the diode as a logarithm of the voltage applied. In this more complete model we note that the 0.6V threshold is only an approximation for reasonable voltages.

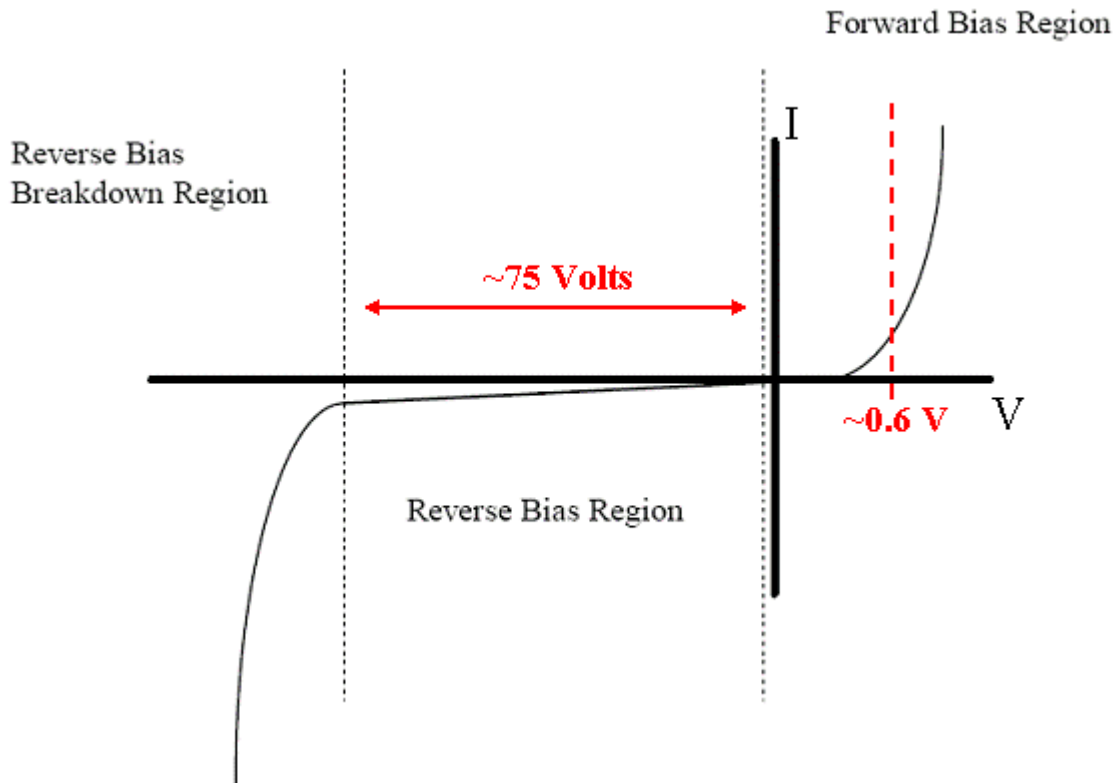

Typical silicon diode I-V characteristic curve [figure adapted from etidweb.tamu.edu]

The I-V characteristic of a diode is given by the Ebers-Moll equation of solid state physics:

$$I = I_0[e^{V/(\eta V_T)} - 1] \quad (1)$$

Where for room temperature silicon, $I_0 = 10^{-9}A$, $\eta=2$, and $V_T=25.3 mV$. This equation is valid in both the forward bias and the reverse bias regions, but does not apply in the breakdown region. Real diodes generally exhibit small deviations from this model.

II. Some Applications

Diodes have many applications. Here are a few of them:

A. Diode Rectifiers

Half-wave rectifier

One of the most common uses for diode is to rectify AC voltage to make a DC power supply. Since a single diode can only conduct current one way, when the input wave goes negative, there will be no current. This is called a half-wave rectifier.

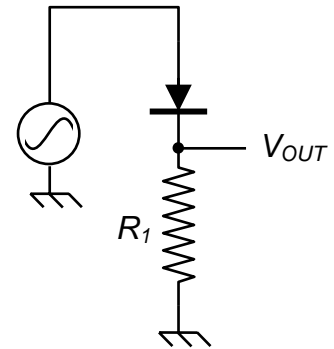

A half wave rectifier

Full-wave rectifier

With four diodes, you can make both halves of the waves positive. This is called a full-wave rectifier diode bridge. For both positive and negative swings of the input there is a forward path through the diode bridge. While two of the diodes are forward biased, the other two are reverse biased and effectively eliminated from the circuit. Both conduction paths cause current to flow in the same direction through the load resistor, accomplishing full-wave rectification.

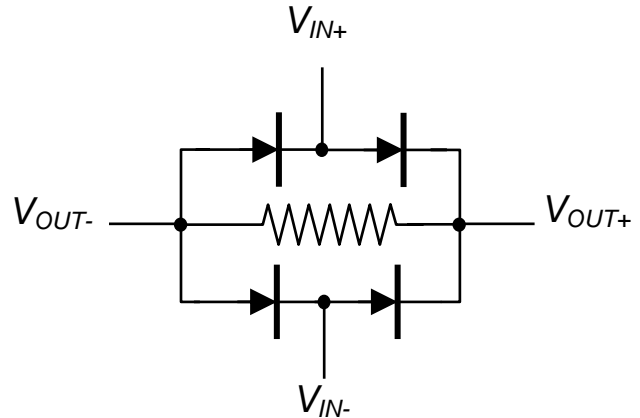

A full-wave rectifier

Full-wave rectifiers are used in power supplies to convert AC voltages to DC voltages (or at least ones which are positive). A large capacitor in parallel with the output load resistor reduces the ripple from the rectification process.

B. Frequency multipliers

A full-wave rectifier is also a frequency multiplier. The output of a rectified 60 Hz signal is at 120 Hz, but also has components at 240 Hz, 360 Hz, etc ... as is shown in the figure below

Chapter 5: Diodes

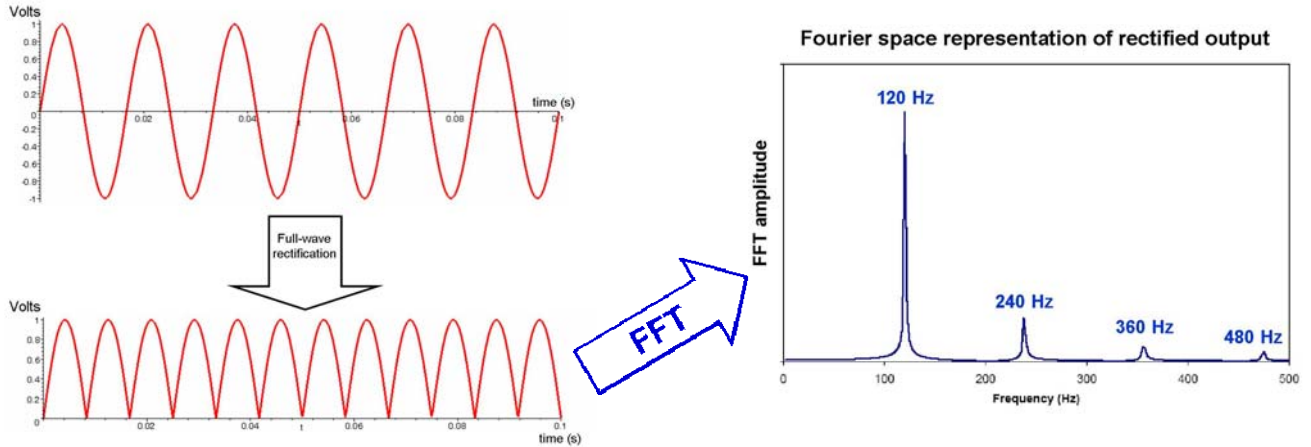

In the above Fourier space representation, we have not included the zero frequency component (i.e. the DC bias) in the plot.

Filtering after the fullwave rectifier is used to remove the unwanted harmonics.

C. Frequency Mixers

A full-wave rectifier can also be used as a frequency mixer when two frequencies, f_1 and f_2 are input simultaneously into the full-wave rectifier: the output will include frequencies at $|f_1 - f_2|$ and $f_1 + f_2$, in addition to the harmonics of $2f_1$ and $2f_2$.

Design Exercises:

Design Exercise 5-1: Design a 12 V DC power supply out of an AC line source (120 V AC), a transformer with $N_p/N_s = 10$, some diodes, and a low pass filter (i.e. a large capacitor). Calculate the ripple voltage at the output of your supply when it has a 50 Ohm load.

Design Exercise 5-2: Design a frequency doubler with an input of 10 kHz and an output of 20 kHz, which rejects the input frequency and higher harmonics (not the second harmonic!) by at least 40 dB. The output should not include a DC bias.