

Chapter 6: Transistors and Gain

I. Introduction

This week we introduce the transistor. Transistors are three-terminal devices that can amplify a signal and increase the signal's power. The price is that we must also supply DC power to it (hence, the need for three terminals).

The three terminals are called the **emitter**, the **base** and the **collector**. The base is the control terminal – a small current enters here and controls the big current that flows from collector to emitter. The notation may seem odd, but remember that electrons actually carry most currents and they have negative charge. So a positive current flowing from the collector to the emitter means that electrons are flowing from the emitter to the collector.

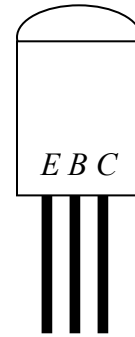

A TO-92 Case

In this chapter we will use a simple model of this device to try to understand its rather complicated behavior. As we continue through the semester we will encounter additional devices that require some sort of approximate models to describe their expected behavior. Since there are always approximations to the real devices they will have certain shortcomings or conditions where the models no longer apply.

The Basic Transistor Model

Bipolar transistors are essentially two diodes placed back to back. This may seem like a silly thing to do but the diodes are not the same. When current flows through one diode it provides carriers to carry current through the other part of the element. Thus, in its most basic form, **a transistor is a current amplifier**.

Bipolar transistors come in two basic types: *npn* and *pnp*. The current flow in a *npn* transistor shown schematically in the accompanying figure. Current (conventional, positive) goes in through the base terminal and out the emitter and the amplified current flows from the collector to the emitter.

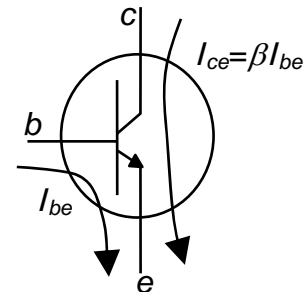
*npn* transistor

Our first model of the transistor says that the collector-emitter current (I_{ce}) is β times the base-emitter current (I_{be}). Later, we will see that good designs do not depend on β since it varies from one device to the next, and it depends on the operating conditions (e.g. temperature). Most transistors have a value of $\beta \cong 100$. In this week's laboratory, you will measure β for a 2N3904 transistor.

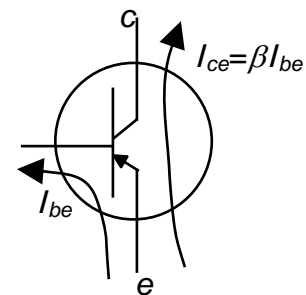
*pnp* transistor

In an *npn* transistor, a current will flow from the base to the emitter only if the base voltage is positive with respect to the emitter. A collector

current will flow to the emitter only if the collector is positive with respect to the emitter. In a *pn*p transistor, things are reversed, and a current will flow from the emitter to the base only if the base voltage is negative with respect to the emitter. A collector current will flow from the emitter only if the collector is negative with respect to the emitter. Note that the arrow on the emitter tells you which way the current is supposed to flow, which indicated whether the base voltage must be positive or negative with respect to the collector.

Let's summarize the conditions required for an *n*p*n* transistor to conduct (the "transistor rules"):

1. $V_{be} > 0$. Since this is a diode, V_{be} should be roughly 0.6V when it is conducting.
2. $V_{bc} < 0$. This is a back-biased diode with enough voltage that the base current normally flows to the emitter. You do not want current to flow from the base to the collector (i.e. $V_{bc} > 0$).
3. $I_{ce} = \beta I_{be}$.

Under normal operating conditions we will have a resistor (or load) connected to the emitter or to the collector, and we will see a voltage drop across the load as I_{ce} flows through the transistor. If I_{ce} changes it will change the voltage drop across the transistor (V_{ce}). If V_{ce} drops too low then V_{bc} will become positive since V_{be} must still be roughly 0.6 V. Current then flows from the base to the collector, leading to an apparent drop in β . This is called saturation.

II. Basic Transistor Circuits

Here are some basic circuits which illustrate the operation of transistors.

A. Constant Current Source

The current source is the simplest transistor circuit possible. You simply drive a small current, I_{be} , into the base of a transistor, and it produces a large current, I_{ce} , through the rest of the circuit. In this case I_{be} is given by,

$$V_+ - V_{be} = I_{be} R_b$$

and the current through the load can then be calculated from our current gain model ($I_{ce} = \beta I_{be}$). From this we can see that current flowing through the load does not depend on the load resistance. It does depend on β so it is not an ideal design.

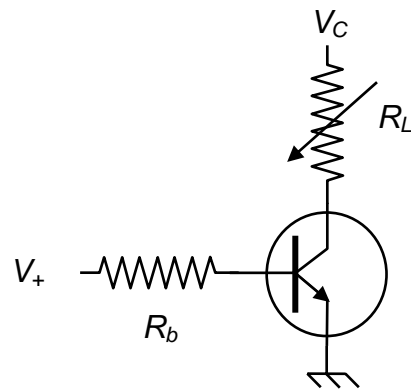

Current Source

The current flowing through the load should be independent of the load resistance. If your load resistor gets too big, though, the voltage drop across the load will make V_{cb} too small to conduct. In this case the current I_{ce} will drop until the transistor starts to conduct again. This reduces the effective β of the

transistor (i.e. some base current flows to the collector). This condition is called *saturation*.

B. Transistor Switch

We can use a transistor switch to control a big current with a small current. This is just a current source with the device you wish to switch in place of the load resistor. A common application is to use a digital (0 or 5V) signal with moderate impedance to control a device requiring a lot more power. In this lab we will use a 5V TTL (transistor-transistor logic) output of your function generator to drive a light bulb.

In designing a transistor switch you want most of the voltage drop to be across your device. If V_{ce} is large then the power dissipated inside the transistor ($I_{ce}V_{ce}$) will fry the transistor. You can get around this in your design by designing the switch for saturated operation. Since the switch runs in saturation mode, some of the base current will flow up to the collector and the apparent β will be smaller than our nominal 100. A common design strategy is to design for a “generous base current,” which could be satisfied with an effective gain of roughly 10.

C. The Emitter-Follower Amplifier

This most important circuit in this section is the emitter follower. This is a very easy circuit to design, and its normal operating conditions do not depend on β . An input voltage on the base produces a base current and an amplified collector current, to generate a voltage drop across the emitter resistor. But the voltage of the emitter cannot increase beyond $V_{IN} - 0.6V$, or the base current will drop. Consequently, the circuit produces a voltage of $V_{IN} - 0.6V$ at the output. In other words, the output (at the emitter) follows the input! In fact, this simple rule, $V_{be} = 0.6V$, is usually sufficient to understand most transistor circuits.

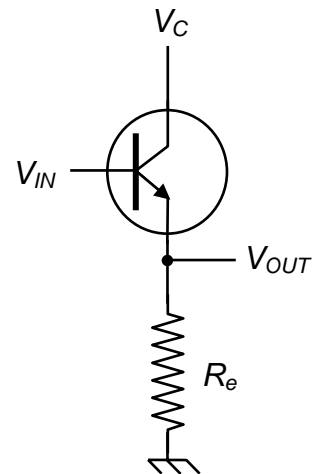

Emitter Follower

The emitter follower is extremely useful because it transforms impedance. The current amplification of the transistor means that it can drive a low impedance, while pulling only a small current from the source. This is just like the transformer – but without the transformer’s voltage decrease.

In the lab, you will build an emitter follower and measure its impedance. You should find

$$\frac{Z_{OUT}}{Z_{SOURCE}} = \frac{1}{1 + \beta}.$$

The derivation of this formula is left to the reader.

D. An Inverting Amplifier

The final circuit is the inverting amplifier, which is also called a common collector. An inverting amplifier is similar to an emitter-follower with two changes. It has an additional resistor between the power supply and the collector, and the output is at the collector terminal. Of course our transistor rules still force the emitter to be $V_{IN} - 0.6V$, and this will set the transistor current to be

$$\frac{V_{IN} - 0.6V}{R_e}$$

When this current passes through the collector resistor, it will generate a voltage drop of

$$R_c \frac{V_{IN} - 0.6V}{R_e}$$

which means that the voltage drop across the collector resistor will be approximately $-R_c/R_e$ times the input voltage. The output is then given by

$$V_{OUT} = V_{CC} - R_c/R_e \times (V_{IN} - 0.6V).$$

The minus sign means that when the voltage at the base is zero, the collector will read the full supply voltage. When the voltage at the base is high there will be a big current and the collector voltage will drop almost to zero. Thus the output will be exactly the opposite of the input. If you find this disturbing you can use two inverting amplifiers in series to get a noninverting amplifier.

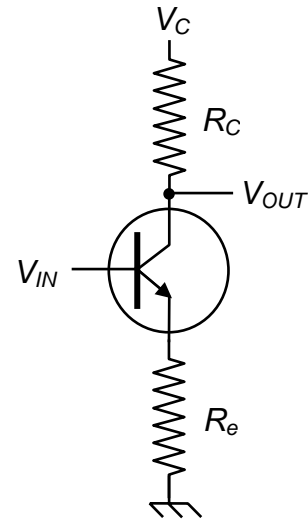

Inverting Amplifier

Design Exercises

Design Exercise 6-1: Design a transistor current source with a base supply voltage of 5 V, a collector supply voltage of 10 V, and a target constant current of 10 mA. Assuming that $\beta=100$, determine the value of the base resistor, and the range of collector/load resistance over which you expect the current source to produce 10 mA. What happens when the collector/load resistance goes above this range?

Design Exercise 6-2: Design a transistor switch for a light bulb with a resistance of 50 Ω and a collector supply voltage of 6 V. Make sure the current into the base will guarantee a operation in saturation mode (gain of roughly 10, instead of $\beta=100$) which is roughly independent of the exact light bulb resistance.

Design Exercise 6-3: Consider an emitter follower amplifier that has $R_e=8 \Omega$. Calculate the input impedance for the amplifier. Assume that your input signal has a DC bias of 3 V, and an AC amplitude of 1 V, and that $\beta=100$. Determine the collector supply voltage necessary to keep the average power dissipated in the transistor to below 0.5 Watts. What is the power dissipated in the 8 Ω load resistor?