

Chapter 1: DC circuit basics

Overview

Electrical circuit design depends first and foremost on understanding the basic quantities used for describing electricity: Voltage, current, and power. In the simplest circuits these are related by Ohm's law. After defining and understanding these quantities, we will begin a discussion of network analysis and look at a few examples.

Voltage

Voltage (measured in volts, V) is measured between two points in a circuit. It is the amount of potential energy delivered per unit charge as a charge flows along the circuit. You measure a voltage by connecting the two terminals of a voltmeter to the two points in your circuit. You must measure the voltage while your circuit is operating. If you have a good *voltmeter* (defined in week 2), your measured voltage will be the same as the voltage was before you connected the voltmeter. A voltage decrease in the direction of current flow represents energy flowing out of the circuit (usually into heat). Voltage sources, such as batteries and power supplies, produce voltage increases along the direction of current flow.

Current

Current (measured in amperes or amps, A, which is equivalent to Coulombs/second) is measured at a single point in a circuit. It is the rate at which charge flows along the circuit. To measure a current with a *current meter* (or *ammeter*) you must break the circuit at that point and connect each end to one of the terminals of the ammeter. Current can only flow in complete circuits. That's why a switch stops an electrical circuit – it breaks the circuit and interrupts the current flow.

Power

Power (measured in Watts, W) is the rate at which electrical energy is converted into heat or some other form of energy. Since we all know that energy is conserved, a circuit needs a *power supply* or battery, which converts another form of energy into electrical energy, in order for it to operate. The power consumed is the product of the current flowing through an element times the voltage drop across the element

$$P = IV$$

Where P is the power, I is the current, and V is the voltage.

IV Characteristic

We can completely characterize any element that has two terminals by its "IV" characteristic (i.e. how much current flows through it when a given voltage is put across it?). The IV characteristic is given by the functions $I(V)$ or $V(I)$ and is frequently defined graphically.

Ground

Ground is the name given to the $V=0$ reference point. This makes it easier to refer to voltages, since you can generally assume that the 2nd point is ground if it is not explicitly stated. We will also use it to represent the implied completion of a circuit, even when we do not explicitly show a wire connection between different places in a circuit, since all ground connections are connected together.

Resistance

A *resistor* is a two-terminal device that converts a voltage into a current or converts a current into a voltage. The current through a resistor is always related to the voltage drop across the resistor by Ohm's Law

$$V = IR$$

where R is the resistance (measured in Ohms, Ω) This also means that a resistor generates heat when a current flows given by:

$$P = IV = I^2R = V^2/R.$$

Each of these expressions give the same answer but one or the other will be easier to use, depending on what you know about the circuit (I or V, or both).

It may seem silly to have a device that just turns electrical energy into heat, but resistors actually perform many important roles:

1. They turn electrical energy into heat. This can be useful if you want to make an electrical heater, or (more likely) a light bulb. Light is just a form of heat given off by a very hot source. Sometimes you must dissipate power somewhere. For example, if you want to deliver 100 mA current at 12 Volts to part of your circuit, but your power supply only gives you 15 Volts, then the extra power

$$300\text{mW} = (100\text{mA})(15\text{V} - 12\text{V})$$

must go somewhere. You dissipate it in a resistor rather than by heating your sensitive transistors.

2. If you have a voltage source and you want a specific amount of current then a resistor does the job. It converts a voltage difference between two points into a current flowing through the resistor. Sometimes, you will add a resistor in series in a circuit to prevent the power supply from delivering too much current in case you short the output lines together. This is called a *current limiting resistor*.
3. If you have a current flowing and you want to convert it into a voltage then a resistor is again the solution. This might seem a little more far-fetched, because you may not be familiar with constant *current sources*. When we begin studying transistors we will find that they will behave as current sources. So we will use a resistor on the output to convert the current into a voltage.

When we consider capacitors, in week three, we will generalize resistance for AC circuits by allowing for phase shifts. We will call this generalization to the complex plane *impedance*. For this week we will assume resistance and impedance to mean the same thing.

Network Analysis

If you connect one power supply and lots of resistors together in a complicated network, then currents will flow through all the various elements so as to insure that charge is conserved, energy is conserved, and Ohm’s Law is satisfied. Simultaneously satisfying all these conditions will give you exactly one solution. We will start with two resistors and then proceed to more complicated systems. Specifically, two resistors in series will draw the same current as an equivalent resistor with resistance. This is stated mathematically as:

$$R_S = R_1 + R_2.$$

Alternatively, two resistors in parallel will draw current equivalent a resistor with resistance

$$\frac{1}{R_{//}} = \frac{1}{R_1} + \frac{1}{R_2} \text{ or } R_{//} = \frac{R_1 R_2}{R_1 + R_2}$$

Note that the resistance of 2 resistors in parallel is always less than the smaller, but not less than half of that smaller resistance. If the two resistors differ by a large factor, then you can ignore the larger resistor. For example, a 1KΩ in parallel with 1MΩ is within 999Ω or very close to 1KΩ.

Standard resistors come in a few dozen difference ratings (more on this in lab). So in general one can get any particular value one wants. One can make up an equivalent resistor using a few resistors in series and parallel combinations to get a much larger range of options. In Design Exercise 1-1, we have you design a network to have a specific net resistance given a very limited set of resistances.

Voltage Dividers

By far, the most useful thing you can do with two resistors is to make a *voltage divider*, which is just two resistors in series. Voltage dividers are shown here schematically in two slightly different but equivalent representations. It “divides” a total voltage into two parts with each part proportional to the resistance in that leg. So, if you know the starting voltage and the target voltage, then you can calculate the required ratio of the two resistors.

$$V_{OUT} = V_{IN} \left(\frac{R_2}{R_1 + R_2} \right)$$

In Design Exercise 1-2 you get to derive this relationship.

A Loaded Voltage Divider

Of course, the way you will use V_{OUT} from a voltage divider is to connect it to something, usually another resistor. This then changes the equivalent resistance in the lower leg, and therefore changes the voltage across that leg!

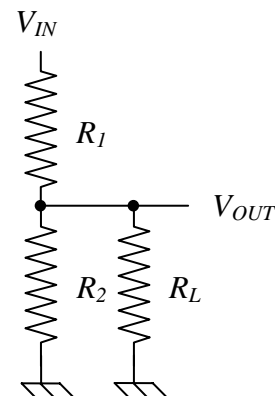
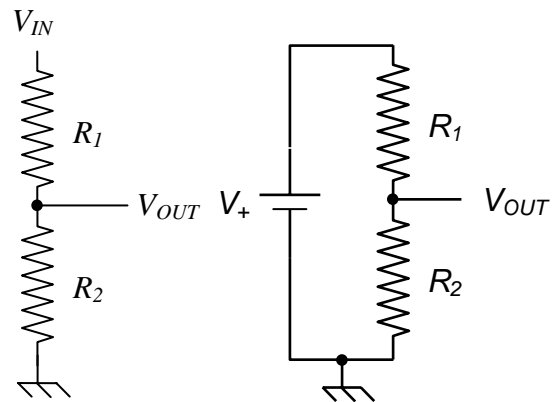

Chapter 1: DC Circuit Basics

To choose the actual resistor values, you have two competing concerns: (1) low resistance makes the divider less sensitive to loading when you use the target voltage (i.e. “stiffer”); and (2) high resistance draws less current, and therefore uses less power. We’ll spend more time on this and become more formal in the coming weeks.

For now, let’s just consider what happens to our voltage divider when we connect a load resistance (R_L) from its output to ground. In this case we can replace the R_2 from the expression for the unloaded divider with an equivalent resistance of R_2 and R_L in parallel. This gives us a voltage across R_L of:

$$\begin{aligned} V_{OUT,LOADED} &= V_{IN} \frac{R_{2//L}}{R_1 + R_{2//L}} \\ &= V_{IN} \left(\frac{\frac{R_L R_2}{R_L + R_2}}{R_1 + \frac{R_L R_2}{R_L + R_2}} \right) \\ &= V_{IN} \frac{R_L R_2}{R_1 R_2 + R_L R_1 + R_L R_2} \\ &= V_{IN} \frac{R_2}{R_1 + R_2} \frac{R_L}{R_{1//2} + R_L} \\ &= V_{UNLOADED} \frac{R_L}{R_{1//2} + R_L} \end{aligned}$$

where $R_{2//L}$ is the equivalent resistance of R_2 and R_L in parallel, $R_{1//2}$ is the equivalent resistance of R_1 and R_2 in parallel, and $V_{UNLOADED}$ is the output voltage of the unloaded voltage divider. From the last expression it is clear that the loaded voltage is always less than the unloaded voltage. The smaller the load the larger the difference between loaded and unloaded, while large load resistors do not affect the output significantly.

So, if you want to ensure that you do not affect the output of a device, you would like to have the input of your device to look like a large resistor and the output look (in this case $R_{P,1,2}$) look like a small resistance. Next week we’ll show that this is a general conclusion and more formally define these concepts.

Design Exercises

Design Exercise 1-1: Use only 1k Ω resistors to create a network with an equivalent resistance of 667 Ω . What is the minimum number of required resistors?

Design Exercise 1-2: Use network analysis and Ohm’s Law to derive a formula for V_{OUT} for an unloaded voltage divider.

Design Exercise 1-3: Assuming that R_1 , R_2 and R_L are 1k Ω resistors and V_{IN} is 10V, compute V_{OUT} for both a loaded voltage divider and an unloaded voltage divider. How much does the output voltage change when it is loaded?