

MOSFETs

MOSFETs are similar to JFETs, except:

- V_p (JFETs) → V_T (MOSFETs)
- V_T is **positive** for N-MOSFETs
- MOSFETs require a **positive voltage on the Gate** -- also no self-biasing.
- Input impedance is $\sim 10^{14}\Omega$.
- Power MOSFETs can handle **100's of Amps**.
- Generally, you must have $I_{DS} > 0$ and $V_{DS} > 0$ (for N-MOSFETs).
- MOSFETs are used in most low power digital electronics chips.
- MOSFETs are very susceptible to **ElectroStatic Discharge (ESD)**.

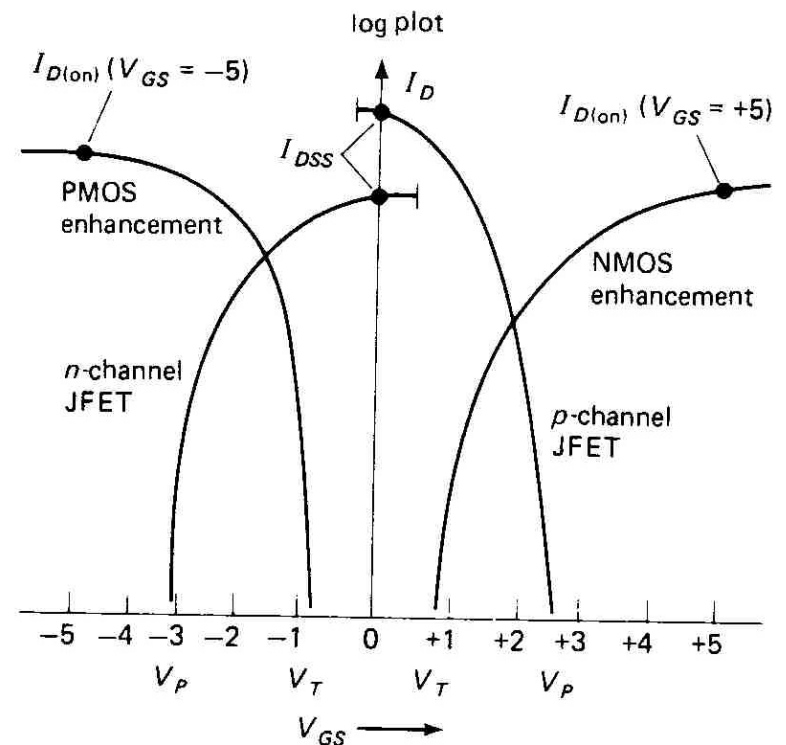
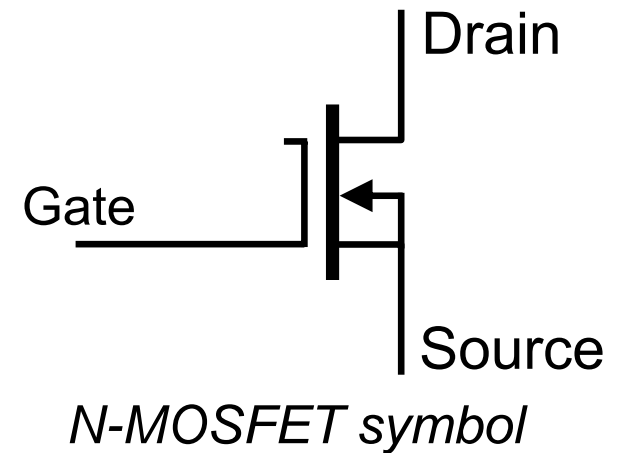

[Figure from Horowitz & Hill p. 120]

ElectroStatic Discharge (ESD)

Common everyday actions generate large VOLTAGES (ESD) -- high impedance sources luckily !!!

ESD is very bad for MOSFETs

TYPICAL ELECTROSTATIC VOLTAGES^a

Action	Electrostatic voltage	
	10%-20% humidity (V)	65%-90% humidity (V)
walk on carpet	35,000	1,500
walk on vinyl floor	12,000	250
work at bench	6,000	100
handle vinyl envelope	7,000	600
pick up poly bag	20,000	1,200
shift position on foam chair	18,000	1,500

[Table from Horowitz & Hill p. 170]

Most semiconductor components have some ESD susceptibility !



high power (X1200)

Figure 3.76. Scanning electron micrograph of a 6 amp MOSFET destroyed by 1kV charge on "human body equivalent" (1.5k in series with 100pF) applied to its gate. (Courtesy of Motorola, Inc.)

[Figure from Horowitz & Hill p. 170]

Introduction

to

OP-Amps

Introduction to Operational Amplifiers

Operational amplifiers (op-amps) are nearly ideal amplifiers:

- Nearly **infinite input impedance** ... typically $1\text{ M}\Omega - 10^{14}\Omega$.
- Nearly **infinite gain** ... typically $10^5 - 10^6$ at DC.
- **Small output impedance** ... typically $10\ \Omega - 0.1\ \Omega$ or less.
 - Op-amp can drive currents of $\sim 10\text{ mA}$.
- $V_{out} = \text{Gain} \times (V_+ - V_-)$.
- It's EASY to design circuits with op-amps !!!

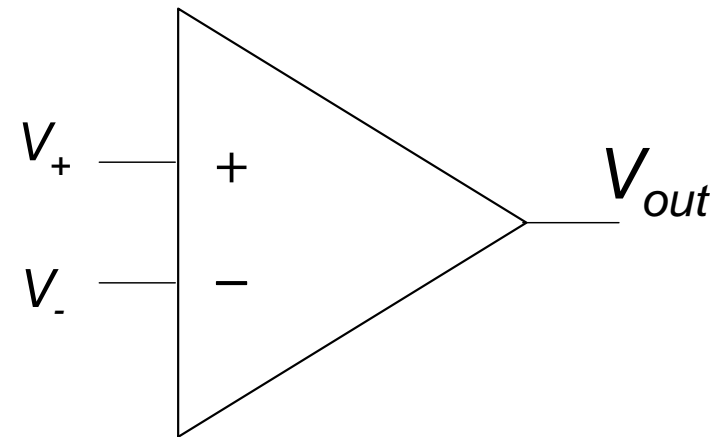

If op-amps are perfect, why would you anything else?

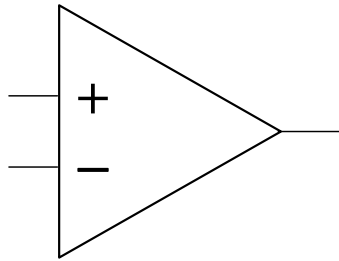

vs.

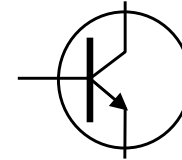

Op-amp drawbacks:

- They usually require **two power supplies** (i.e. + 15 V and -15 V).
- They **cannot** provide a lot of power (i.e. Amps).
- **Emitter-follower** and the **common-emitter** amplifier are simple and work well.

→ *One frequently combines transistors and op-amps for power circuits.*

Integrated Circuits (ICs)

An op-amp is an **integrated circuit**:

- It has many discrete components (resistors, capacitors, and transistors)
- All made at the same time on the same piece of silicon.
- Put into a standardized package (DIP-8).

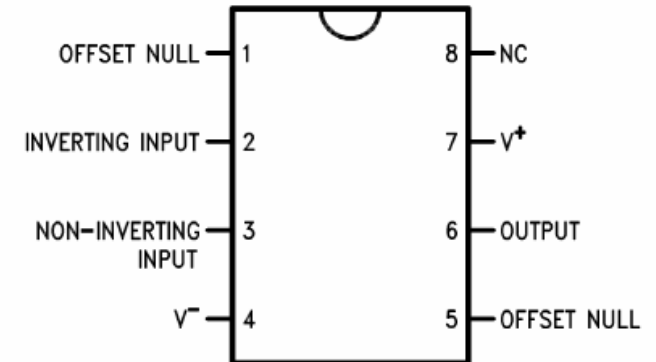

Most of the circuit design is already done:

- Makes them easy to use.
- Fits directly into a breadboard.

Physical Dimensions Inches (millimeters) unless otherwise noted (Continued)

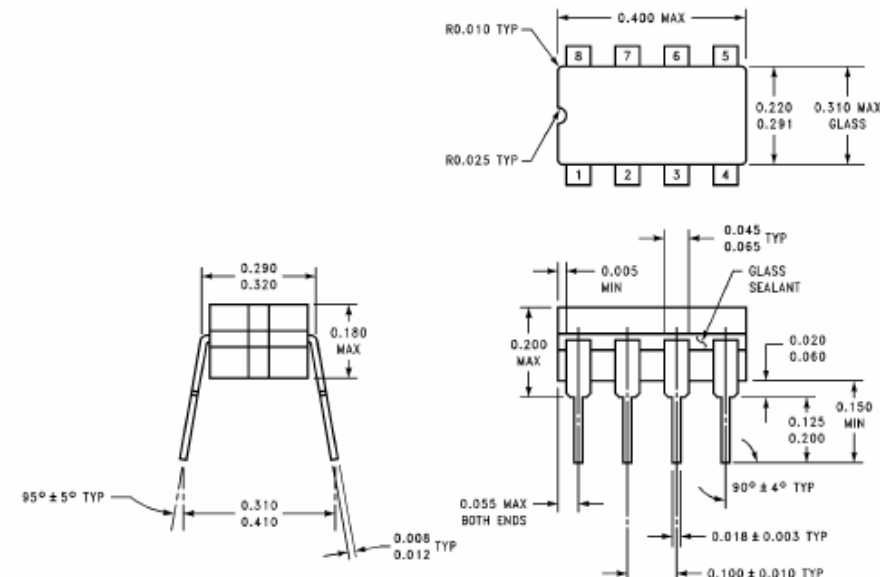

What's inside an op-amp?

LM741 schematic

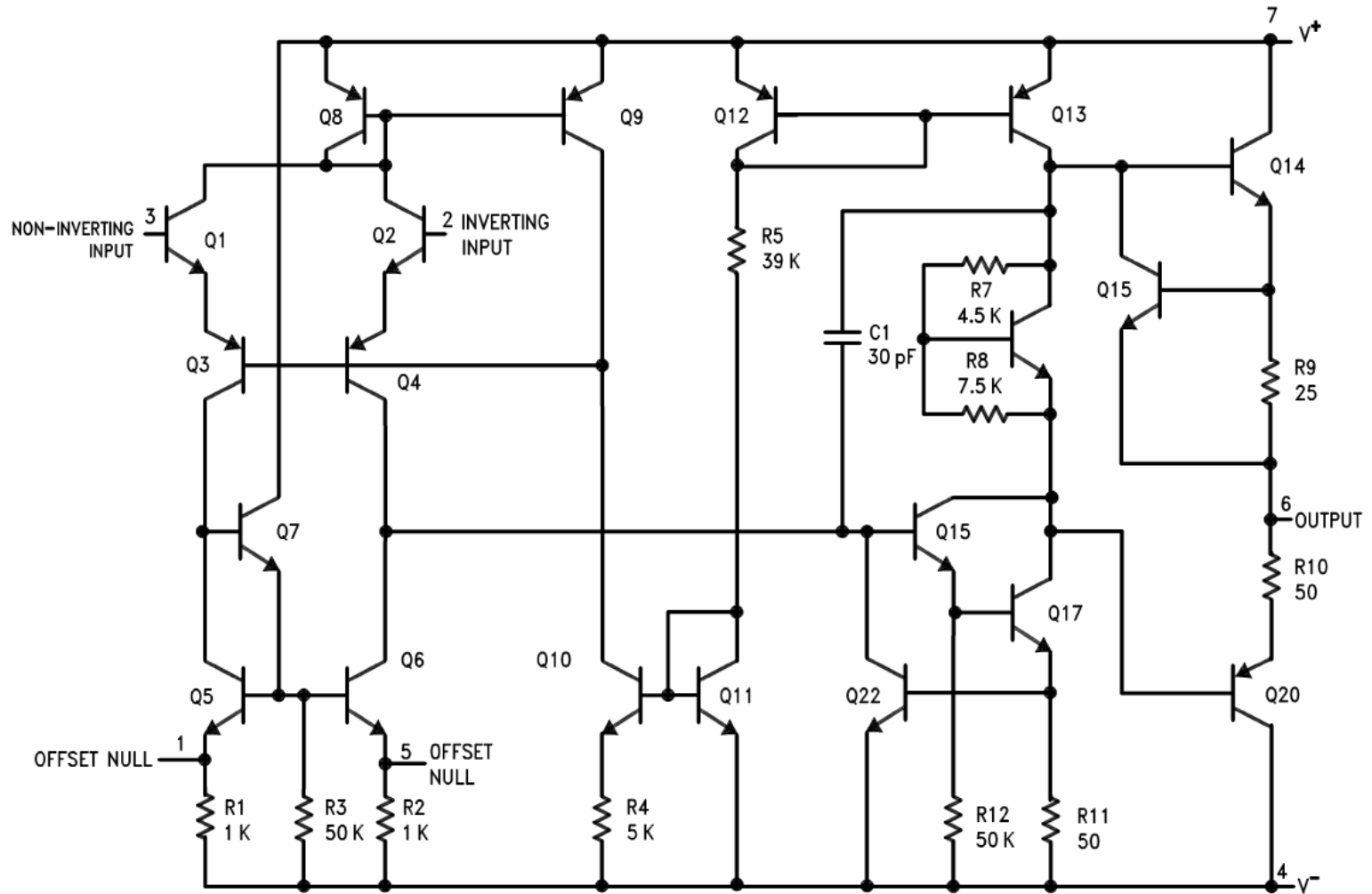

What's inside an op-amp?

LM741 schematic

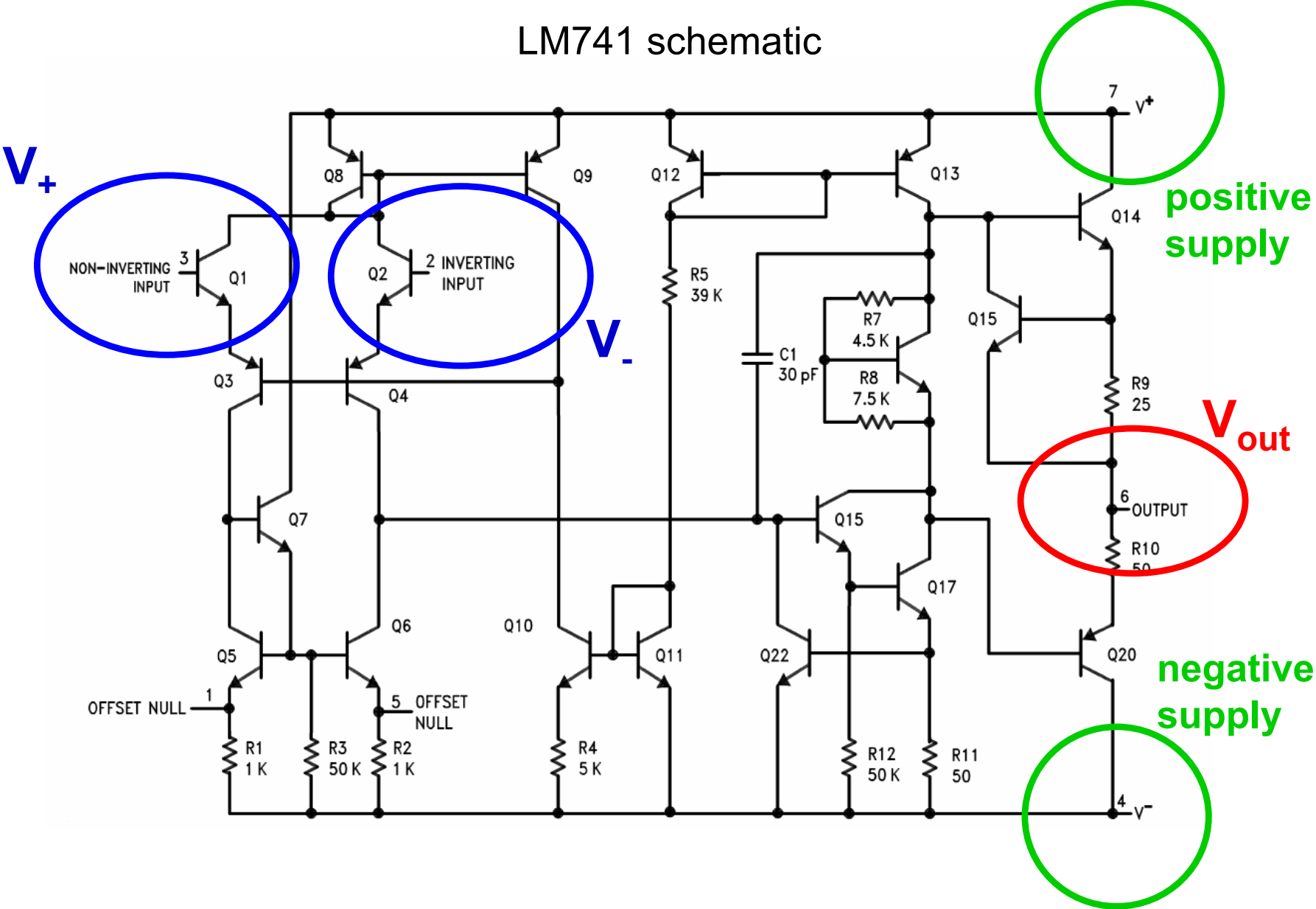

What's inside an op-amp?

LM741 schematic

Differential Amplifier

Push-Pull Amplifier

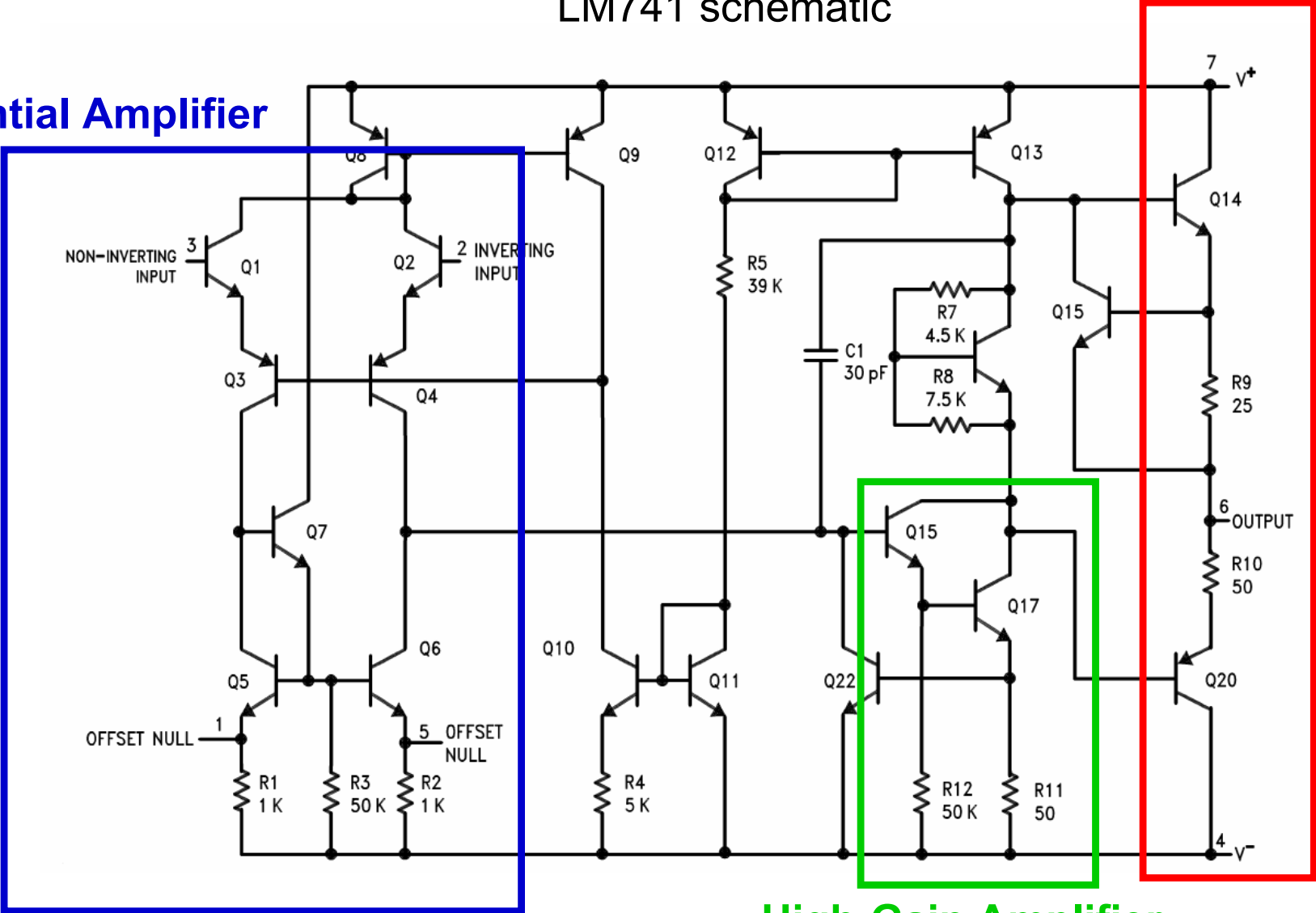

High-Gain Amplifier

Op-amps and Feedback

Op-amps are hardly ever used as straight super-high gain amplifiers:

- Gain is so large that the amplifier **output saturates** (i.e. go to the supply rails) for most reasonable signals.
- Susceptible to **manufacturing spread** of parameters.
- Gain has a **non-linearities** (i.e. can depend on voltage and frequency).

Feedback

Op-amps are almost always operated with negative feedback from the output to the V_- input.

- Feedback **stabilizes the performance** of the op-amp.
 - Feedback eliminates any dependence of the circuit on the op-amps open-loop specs.
- Feedback produces **very linear gain**.
- The price of feedback is reduced gain.
- We will discuss feedback in detail in two weeks.

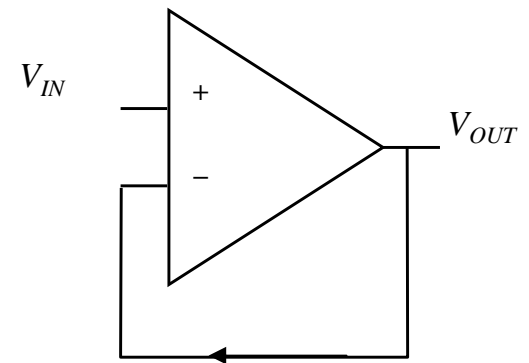

Golden Rules of Op-amps

When using **feedback**, you can understand and design most op-amp circuits using the 2 following rules:

1. The op-amp inputs do not draw any current.
2. The op-amp will adjust its output so that the voltage difference between the 2 inputs is **zero**.