

## DET36A Operating Manual – High Speed Silicon Detector

### Description:

The Thorlabs DET36A is a ready-to-use high-speed photo detector. The unit comes complete with a photodiode and internal 12V bias battery enclosed in a rugged aluminum housing. The DET36A includes a removable 1" optical coupler (SM1T1), providing easy mounting of ND filters, spectral filters, fiber adapters (SMA, FC and ST style), and other Thorlabs 1" stackable lens mount accessories.

The DET36A includes two #8-32 tapped mounting holes with a 0.25" mounting depth, while the DET36A/M has two M4 tapped mounting holes. A 12V A23 battery is included.

### Specifications:

Electrical		
Detector:		Silicon PIN
Active Area:		13mm <sup>2</sup> (3.6 x 3.6mm)
Wavelength Range:	$\lambda$	350 to 1100 nm
Peak Wavelength:	$\lambda_p$	970 nm (typ)
Peak Response (typ):	$\mathcal{R}(\lambda_p)$	0.65 A/W (typ)
Shunt Resistance:	$R_{sh}$	>10M $\Omega$
Diode Capacitance:	$C_J$	40pF
Rise/Fall Time:	$t_r$	14ns (max.)
Linearity Limit (Current):		1mA
(Power):		1.5mW (min @ $\lambda_p$ )
NEP (750nm):		1.6x10 <sup>-14</sup> W/ $\sqrt{Hz}$ (max.)
Bias Voltage:	$V_R$	10 V (9V min)
Dark Current <sup>2</sup> :	$I_D$	0.35nA (06nA max.)
Output Voltage:	$V_{OUT}$	0 to 10V
Damage Threshold:		100mW/cm <sup>2</sup>

General	
On / Off Switch:	Slide
Battery Check Switch:	Momentary Pushbutton
Output:	BNC (DC Coupled)
Package Size:	2.8"x1.9" x 0.83" 70mm x 48mm x 21mm
PD Surface Depth:	0.16" (4.1mm)
Weight:	0.2 lbs
Accessories:	SM1T1 Coupler SM1RR Retainer Ring
Storage Temp:	-25 to 70°C
Operating Temp:	10 to 50°C
Battery:	A23, 12V <sub>DC</sub> , 40mAh
Low Battery Voltage <sup>3</sup> :	(See 'Battery Check')
$V_{OUT}$ (Hi-Z):	~9V
$V_{OUT}$ (50 $\Omega$ ):	~400mV

1. All measurements performed with a 50 $\Omega$  load unless stated otherwise.
2. Measured with specified Bias Voltage.
3. Assumes the battery voltage drops below 9.6V. The reverse protection diode generates a 0.6V drop.

Figure 1 - Typical DET36A Spectral Responsivity Curve

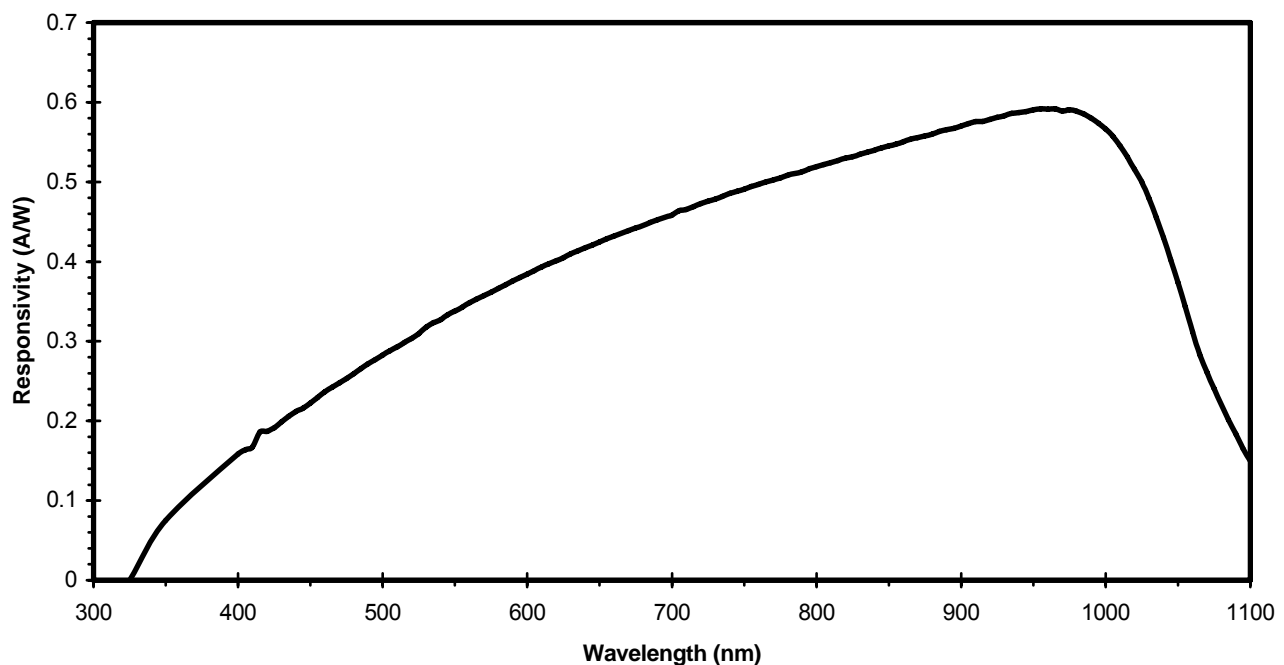

## Operation

Thorlabs DET series are ideal for measuring both pulsed and CW light sources. The DET36A includes a reversed-biased PIN photo diode, bias battery, and ON/OFF switch packaged in a rugged housing. The BNC output signal is the direct photocurrent out of the photo diode anode and is a function of the incident light power ( $P$ ) and wavelength ( $\lambda$ ). The Spectral Responsivity,  $\mathfrak{R}(\lambda)$ , can be obtained from Figure 1 to estimate the amount of photocurrent to expect. Most users will wish to convert this photocurrent to a voltage ( $V_{OUT}$ ) for viewing on an oscilloscope or DVM. This is accomplished by adding an external load resistance,  $R_{LOAD}$ . The output voltage is derived as:

$$V_{OUT} = P * \mathfrak{R}(\lambda) * R_{LOAD}$$

It should be noted that the load resistor will react with the photodetector junction capacitance ( $C_J$ ) to limit the bandwidth. For best frequency response, a  $50\Omega$  terminator should be used. The bandwidth ( $f_{BW}$ ) and the rise-time response ( $t_R$ ) can be approximated using the diode capacitance ( $C_J$ ) and the load resistance ( $R_{LOAD}$ ) as shown below:

$$f_{BW} = 1 / (2 * \pi * R_{LOAD} * C_J)$$
$$t_R = 0.35 / f_{BW}$$

For maximum bandwidth, we recommend using a  $50\Omega$  coax cable with a  $50\Omega$  terminating resistor at the opposite end of the coax. This will also minimize ringing by matching the coax with its characteristic impedance. If bandwidth is not important, you may increase the amount of voltage for a given input light by increasing the  $R_{LOAD}$ .

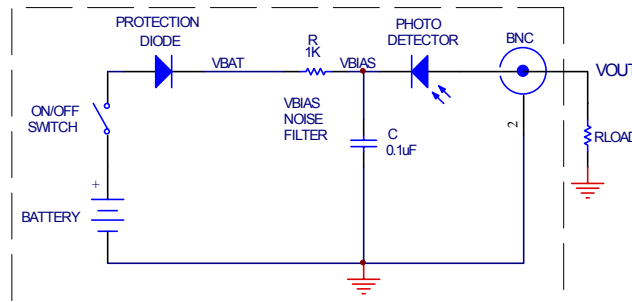

Figure 2 – Circuit Schematic

## Setup

- Unpack the optical head, install a Thorlabs TR-series  $\frac{1}{2}$ " diameter post into one of the #8-32 (M4 on /M version) tapped holes, located on the bottom and side of the sensor, and mount into a PH-series post holder.
- Attach a  $50\Omega$  coax cable (i.e. RG-58U) to the output of the DET. Select and install a terminating resistor to the remaining end of the cable and connect to a voltage measurement device. See the 'Operation' Section to determine resistor values. Thorlabs sells a  $50\Omega$  terminator (T4119) for best frequency performance and a variable terminator (VT1) for output voltage flexibility. Note the input impedance of your measurement device since this will act as a terminating resistor. A load resistor is not necessary when using current measurement devices.
- Power the DET on using the power switch. To check battery voltage, see 'Battery Check' below.
- Install any desired filters, optics, adapters, or fiber adapters to the input aperture. **Caution:** The DET36A was designed to allow maximum accessibility to the photodetector by having the front surface of the diode flush with the outside of the DET housing. When using fiber adapters, make sure that the fiber ferrule does not crash into the detector. Failure to do so may cause damage to the diode and / or the fiber. An easy way to accomplish this is to install a SM1RR retaining ring (included with the DET36A) inside the 1" threaded coupler *before* installing the fiber adapter
- Apply a light source to the detector.

## Battery Check and Replacement

### Battery Check

Thorlabs new DET series includes a battery check feature that will allow the user to monitor the bias voltage on the output BNC. Simply hold down the "VBIAS OUT" bottom located on the bottom edge of the unit. The bias voltage will be output to the BNC. If a high impedance load is used ( $>10k\Omega$ ), the output will be equal to the bias voltage. This feature includes a  $1.05k\Omega$  current limiting resistor ( $R_{CL}$ ) to prevent excessive loading of the battery if using small terminating resistors. For example, a  $50\Omega$  load resistor with a 10V bias will produce a 200mA current without this resistor. This will significantly decrease lifetime of the battery. The output bias voltage will be dependent on the load

resistor as described below. The A23 battery voltage characteristics show that the charge level is almost depleted as the voltage drops below 10V. For this calculation we assume 9.6V since  $V_{BAT} = \text{low battery voltage} - \text{one diode drop} (0.6V) = \sim 9V$ . The detector will continue to operate until the battery charge is completely drained, however these numbers provide a reference point at which the battery should be replaced.

$$V_{OUT} = V_{BAT} [R_{LOAD} / (R_{LOAD} + R_{CL})]$$

For  $V_{BAT} (\text{min}) = 9V$ ,  $R_{LOAD} = 50\Omega$ , and  $R_{CL} = 1050\Omega$   
 $V_{OUT} = 410mV$

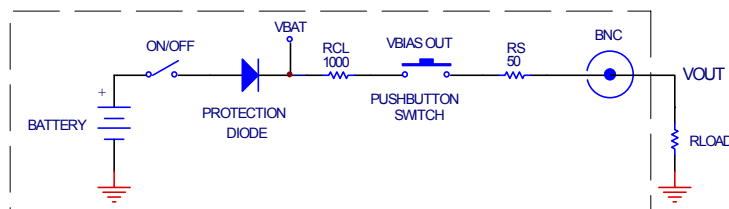

Figure 3 – Battery Check Schematic

### Battery Replacement

Thorlabs delivers each DET with an A23 12V battery installed. This battery is readily available at most retail stores, as well as through Thorlabs. The battery supplied will deliver about 40 hours with a 1mA load, roughly equivalent to a continuous 1.5mW light source at peak wavelength. The supply current when the unit is on and no light is applied is very small and should not significantly degrade the battery.

Locate the battery cap directly above the output BNC. Unthread the cap and remove the battery. Install the new battery into the cap, negative side in, and thread back into the DET. Be careful not to cross thread the cap into the housing. The DET includes a protection diode to prevent damage if the battery is installed backwards. The battery direction is located on the housing.

### Troubleshooting

#### There is no signal response.

- Verify that the power is switched on and all connections are secure.
- Verify the proper terminating resistor is installed if using a Voltage measurement device.
- Verify that the optical signal wavelength is within the specified wavelength range.
- Verify that the optical signal is hitting the detector active area.
- Connect the DET to an oscilloscope without a terminating resistor installed. Most general purpose oscilloscopes will have a 10MΩ input impedance. Point the detector toward a fluorescent light and verify that a 60Hz (50Hz outside the US) signal appears on the scope. If so the device should be operating properly and the problem may be with the light source or alignment.

#### There is an AC signal present when the unit is turned off.

The detector has an AC path to ground even with the switch in the OFF position. It is normal to see an output response to an AC signal with the switch in this state. However, because the detector is unbiased, operation in this mode is not recommended.

#### The output appears AC coupled with long rise times and the power switch ON.

This is usually an indication that the battery level is low and needs to be changed. See the Battery Check and Replacement Section.

### Maintaining the DET36A

There are no serviceable parts in the DET36A optical sensor. The housing may be cleaned by wiping with a soft damp cloth. The window of the detector should only be cleaned using isopropyl alcohol and optical grade wipes. If you suspect a problem with your DET36A please call Thorlabs and an engineer will be happy to assist you.

### Contact

**Americas**  
 Thorlabs Inc.  
 435 Route 206 North  
 Newton NJ 07860  
 USA  
 Ph: (973) 579-7227  
 Fax: (973) 300-3600  
[www.thorlabs.com](http://www.thorlabs.com)  
 Email:  
[techsupport@thorlabs.com](mailto:techsupport@thorlabs.com)

**Europe**  
 Thorlabs GmbH  
 Gaußstr. 11  
 85757 Karlsfeld  
 Germany  
 Ph: +49 (0) 8131-59-56-0  
 Fax: +49 (0) 8131-59-56-99  
[www.thorlabs.com](http://www.thorlabs.com)  
 Email:  
[Europe@thorlabs.com](mailto:Europe@thorlabs.com)

**UK and Ireland**  
 Thorlabs, LTD.  
 1 Saint Thomas Place, Ely  
 Cambridgeshire CB7 4EX  
 Great Britain  
 Ph: +44 (0) 1353-654440  
 Fax: +44 (0) 1353-654444  
[www.thorlabs.com](http://www.thorlabs.com)  
 Email:  
[sales.uk@thorlabs.com](mailto:sales.uk@thorlabs.com)

**Scandinavia**  
 Thorlabs Sweden AB  
 Box 141 94  
 400 20 Göteborg  
 Sweden  
 Ph: +46-31-733-30-00  
 Fax: +46-31-703-40-45  
[www.thorlabs.com](http://www.thorlabs.com)  
 Email:  
[Scandinavia@thorlabs.com](mailto:Scandinavia@thorlabs.com)

**Japan**  
 Thorlabs Japan, Inc  
 5-17-1, Ohtsuka  
 Bunkyo-ku, Tokyo 112-0012  
 Japan  
 Ph: +81-3-5977-8401  
 Fax: +81-3-5977-8402  
[www.thorlabs.jp](http://www.thorlabs.jp)  
 Email:  
[sales@thorlabs.jp](mailto:sales@thorlabs.jp)

## WEEE

As required by the WEEE (Waste Electrical and Electronic Equipment Directive) of the European Community and the corresponding national laws, Thorlabs offers all end users in the EC the possibility to return “end of life” units without incurring disposal charges.

This offer is valid for Thorlabs electrical and electronic equipment

- sold after August 13<sup>th</sup> 2005
- marked correspondingly with the crossed out “wheelie bin” logo (see fig. 1)
- sold to a company or institute within the EC
- currently owned by a company or institute within the EC
- still complete, not disassembled and not contaminated

As the WEEE directive applies to self contained operational electrical and electronic products, this “end of life” take back service does not refer to other Thorlabs products, such as

- pure OEM products, that means assemblies to be built into a unit by the user (e. g. OEM laser driver cards)
- components
- mechanics and optics
- left over parts of units disassembled by the user (PCB’s, housings etc.).

If you wish to return a Thorlabs unit for waste recovery, please contact Thorlabs or your nearest dealer for further information.

### Waste treatment on your own responsibility

If you do not return an “end of life” unit to Thorlabs, you must hand it to a company specialized in waste recovery. Do not dispose of the unit in a litter bin or at a public waste disposal site.

### Ecological background

It is well known that WEEE pollutes the environment by releasing toxic products during decomposition. The aim of the European RoHS directive is to reduce the content of toxic substances in electronic products in the future. The intent of the WEEE directive is to enforce the recycling of WEEE. A controlled recycling of end of live products will thereby avoid negative impacts on the environment.



Crossed out “wheelie bin” symbol

COPYRIGHT © 2006 by THORLABS INC.

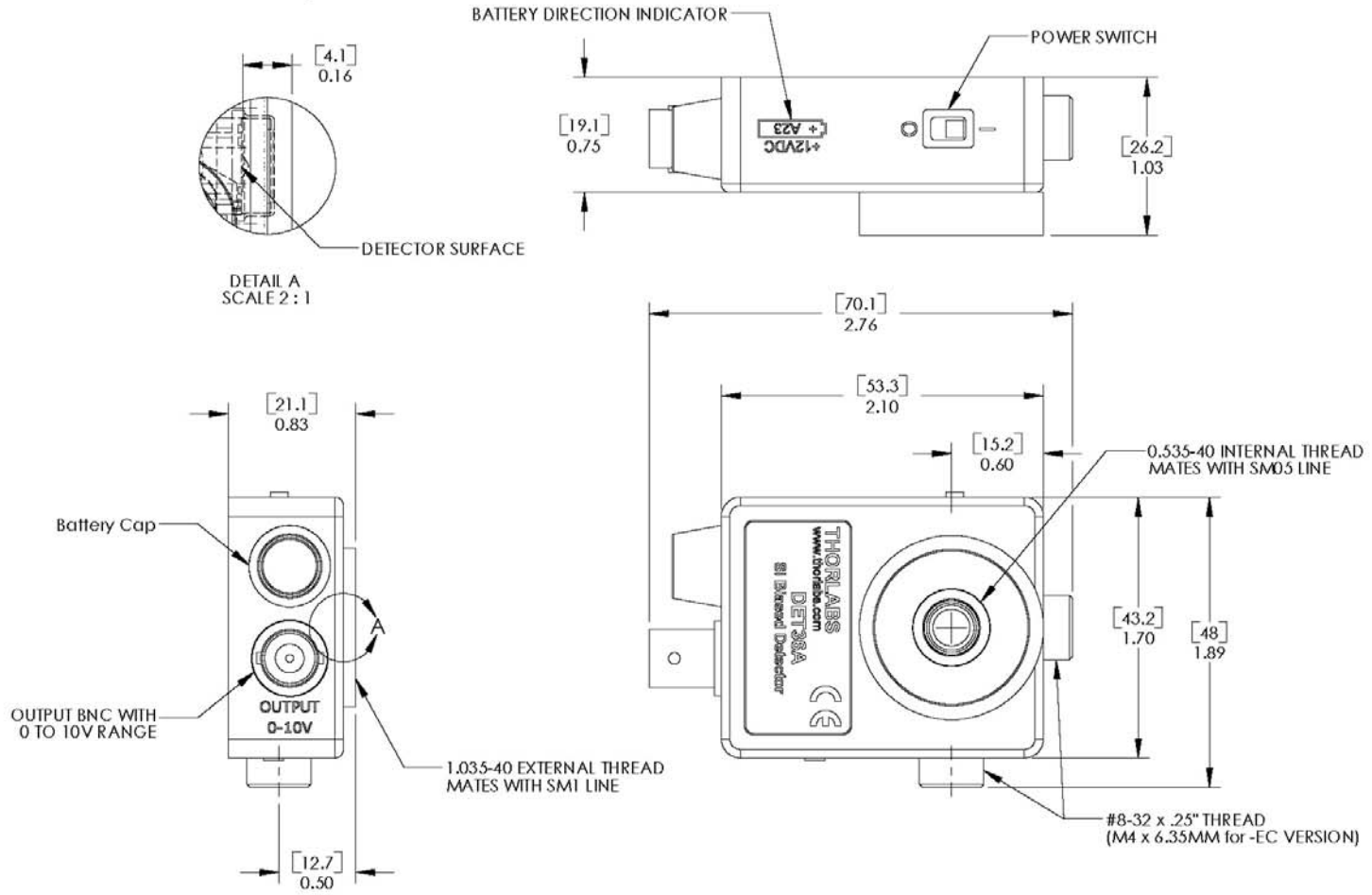

**TOLERANCES**

UNLESS OTHERWISE SPECIFIED:  
**DIMENSIONS ARE IN INCHES**  
**LINEAR TOLERANCES:**  
 TWO PLACE DECIMAL: ±0.010  
 THREE PLACE DECIMAL: ±0.005  
 ANGULAR: ±30'  
 SURFACE FINISH: 32 MICRONS  
 PARALLELISM: 0.002  
 FLATNESS: 0.002  
 STRAIGHTNESS: 0.002  
 CONCENTRICITY: 0.002  
 PERPENDICULARITY: 0.002  
 THREAD: CLASS 2 FIT

	NAME	DATE
DRAWN	EC	1/11/06
ENG APPR.	EC	1/11/06
MFG APPR.	EC	1/11/06

**PROPRIETARY AND CONFIDENTIAL**

THE INFORMATION CONTAINED IN THIS DRAWING IS THE SOLE PROPERTY OF THORLABS, INC. ANY REPRODUCTION IN PART OR AS A WHOLE WITHOUT THE WRITTEN PERMISSION OF THORLABS, INC. IS PROHIBITED.

THORLABS INC. PO BOX 366  
 NEWTON NJ

<b>TITLE:</b> 3.6 X 3.6 mm Si BIASED DETECTOR	
<b>MATERIAL:</b> DET36A	<b>SIZE</b> A
<b>SCALE:</b> 1:1	<b>REV.</b> 1
<b>DWG. NO.</b> 13051-E01	<b>SHEET</b> 1 OF 1
<b>PART NO.</b> DET36A	

5 4 3 2 1